

Autumn Scheme of Learning

Year 4/5

#MathsEveryoneCan

2019-20



How to use the mixed-age SOL

In this document, you will find suggestions of how you may structure a progression in learning for a mixed-age class.

Firstly, we have created a yearly overview.

	Week 1	Week 2	Week 3	Week 4	Week 5	Week 6	Week 7	Week 8	Week 9	Week 10	Week 11	Week 12
Autumn	Number: Place Value Y1 – Numbers to 20 Y2 – Numbers to 100			Number: Addition and Subtraction Year 1- Numbers within 20 (including recognising money) Year 2- Numbers within 100 (including money)						Number: Year 1: Place Value to 50 and Multiplication Year 2: Multiplication		
Spring	Number: Year 1: Division & consolidation Year 2: Division		Year 1: Place Value to 100 Year 2: Statistics		Measurement: Length and Height		Geometry: Year 1: Shape and Consolidation Year 2: Properties of Shape		Number: Year 1: Fractions and Consolidation Year 2: Fractions		Consolidation	
Summer	Geometry: Position and Direction	Measurement: Time		Problem solving and efficient methods		Measurement: Year 1: Weight and Volume Year 2: Mass, Capacity and Temperature		Consolidation and Investigations				

Each term has 12 weeks of learning. We are aware that some terms are longer and shorter than others, so teachers may adapt the overview to fit their term dates.

The overview shows how the content has been matched up over the year to support teachers in teaching similar concepts to both year groups. Where this is not possible, it is clearly indicated on the overview with 2 separate blocks.

For each block of learning, we have grouped the small steps into themes that have similar content. Within these themes, we list the corresponding small steps from one or both year groups. Teachers can then use the single-age schemes to access the guidance on each small step listed within each theme.

The themes are organised into common content (above the line) and year specific content (below the line). Moving from left to right, the arrows on the line suggest the order to teach the themes.

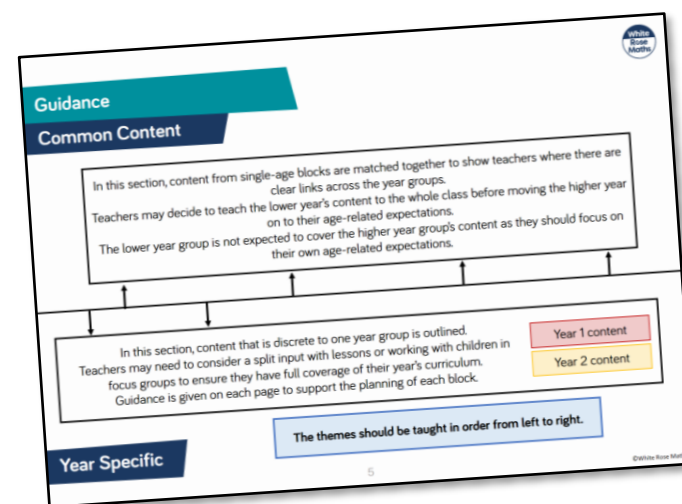

How to use the mixed-age SOL

Here is an example of one of the themes from the Year 1/2 mixed-age guidance.

Subtraction

Year 1 (Aut B2, Spr B1)

- How many left? (1)
- How many left? (2)
- Counting back
- Subtraction - not crossing 10
- Subtraction - crossing 10 (1)
- Subtraction - crossing 10 (2)

Year 2 (Aut B2, B3)

- Subtract 1-digit from 2-digits
- Subtract with 2-digits (1)
- Subtract with 2-digits (2)
- Find change - money

In order to create a more coherent journey for mixed-age classes, we have re-ordered some of the single-age steps and combined some blocks of learning e.g. Money is covered within Addition and Subtraction.

The bullet points are the names of the small steps from the single-age SOL. We have referenced where the steps are from at the top of each theme e.g. Aut B2 means Autumn term, Block 2. Teachers will need to access both of the single-age SOLs from our website together with this mixed-age guidance in order to plan their learning.

Points to consider

- Use the mixed-age schemes to see where similar skills from both year groups can be taught together. Learning can then be differentiated through the questions on the single-age small steps so both year groups are focusing on their year group content.
- When there is year group specific content, consider teaching in split inputs to classes. This will depend on support in class and may need to be done through focus groups .
- On each of the block overview pages, we have described the key learning in each block and have given suggestions as to how the themes could be approached for each year group.
- We are fully aware that every class is different and the logistics of mixed-age classes can be tricky. We hope that our mixed-age SOL can help teachers to start to draw learning together.

Guidance

Common Content

In this section, content from single-age blocks are matched together to show teachers where there are clear links across the year groups. Teachers may decide to teach the lower year's content to the whole class before moving the higher year on to their age-related expectations. The lower year group is not expected to cover the higher year group's content as they should focus on their own age-related expectations.

In this section, content that is discrete to one year group is outlined. Teachers may need to consider a split input with lessons or working with children in focus groups to ensure they have full coverage of their year's curriculum. Guidance is given on each page to support the planning of each block.

Year 4 content

Year 5 content

The themes should be taught in order from left to right.

Year Specific

	Week 1	Week 2	Week 3	Week 4	Week 5	Week 6	Week 7	Week 8	Week 9	Week 10	Week 11	Week 12
Autumn	Number: Place Value				Number: Addition and Subtraction			Number: Multiplication and Division			Measurement: Length, Perimeter and Area	
Spring	Number: Multiplication and Division			Number: Fractions					Number: Decimals (including Y5 Percentages)			
Summer	Number: Decimals (including Y4 Money)		Measurement: Time	Statistics		Geometry: Properties of Shape		Geometry: Position and Direction	Y4: Consolidation		Consolidation	
							Y5: Converting Units & Volume					

Length, Perimeter and Area

Common Content

Perimeter

Year 4 (Aut B3)

- Perimeter on a grid
- Perimeter of a rectangle
- Perimeter of rectilinear shapes

Year 5 (Aut B5)

- Measure perimeter
- Calculate perimeter

Area

Year 4 (Spr B2)

- What is area?
- Counting squares
- Making shapes
- Comparing area

Year 5 (Aut B5)

- Area of rectangles
- Area of compound shapes
- Area of irregular shapes

Kilometres

Year 4 (Aut B3)

- Kilometres

Year 4 start the block looking at kilometres, this is a good opportunity for Year 5 to recap their previous year's learning ready for the rest of the block.

Both year groups explore measuring and calculating the perimeter of rectilinear shapes in both centimetres and metres.

When looking at area, Year 4 focus on counting squares to calculate the area of rectilinear shapes whilst Year 5 move onto using a formula to calculate the area of rectangles. They also calculate the area of rectilinear shapes and estimate the area of irregular shapes.

Year Specific

White

**Rose
Maths**

Block 4 - Measurement

Theme 1 - Kilometres

Kilometres

Notes and Guidance

Children multiply and divide by 1,000 to convert between kilometres and metres.
 They apply their understanding of adding and subtracting with four-digit numbers to find two lengths that add up to a whole number of kilometres.
 Children find fractions of kilometres, using their Year 3 knowledge of finding fractions of amounts. Encourage children to use bar models to support their understanding.

Mathematical Talk

Can you research different athletic running races? What different distances are the races? Can you convert the distances from metres into kilometres? Which other sports have races over distances measured in metres or kilometres?
 If 10 children ran 100 metres each, how far would they run altogether? Can we go outside and do this? How long do you think it will take to run 1 kilometre?
 How can we calculate half a kilometre? Can you find other fractions of a kilometre?

Varied Fluency

Complete the statements.

$3,000 \text{ m} = \underline{\quad} \text{ km}$

$8 \text{ km} = \underline{\quad\quad\quad} \text{ m}$

$5 \text{ km} = \underline{\quad} \text{ m}$

$3 \text{ km} + 6 \text{ km} = \underline{\quad\quad\quad} \text{ m}$

$500 \text{ m} = \underline{\quad} \text{ km}$

$250 \text{ m} = \underline{\quad\quad\quad} \text{ km}$

$9,500 \text{ m} = \underline{\quad} \text{ km}$

$4,500 \text{ m} - 2,000 \text{ m} = \underline{\quad\quad\quad} \text{ km}$

Complete the bar models.

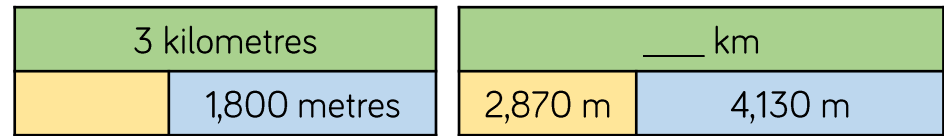

Use $<$, $>$ or $=$ to make the statements correct.

500 m	<input type="radio"/>	$\frac{1}{2}$ km
7 km	<input type="radio"/>	800 m
5 km	<input type="radio"/>	500 m

Kilometres

Reasoning and Problem Solving

Dexter and Rosie walk 15 kilometres altogether for charity.
 Rosie walks double the distance that Dexter walks.
 How far does Dexter walk?

Rosie walks 10 km.
 Dexter walks 5 km.

Dexter and Rosie each raise £1 for every 500 metres they walk.
 How much money do they each make?

Rosie raises £20
 Dexter raises £10

Complete the missing measurements so that each line of three gives a total distance of 2 km.

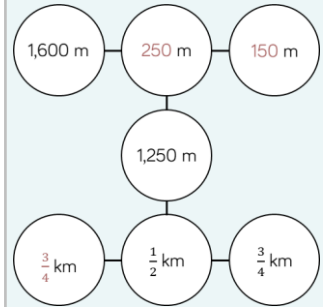
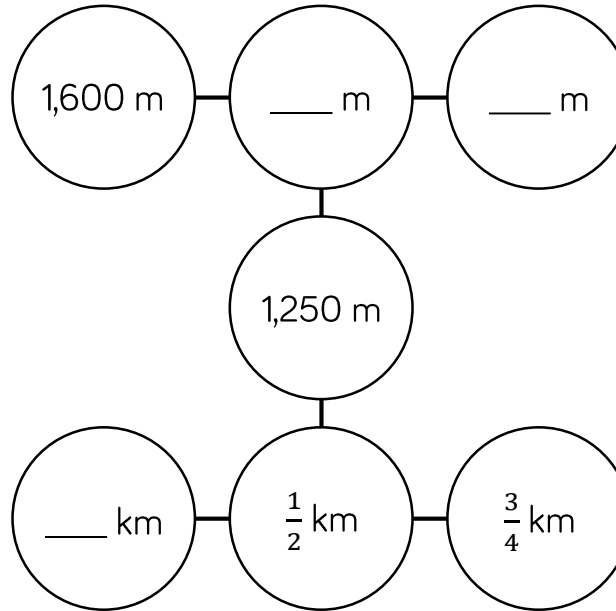

White

**Rose
Maths**

Block 4 - Measurement

Theme 2 - Perimeter

Perimeter on a Grid

Notes and Guidance

Children calculate the perimeter of rectilinear shapes by counting squares on a grid. Rectilinear shapes are shapes where all the sides meet at right angles.

Encourage children to label the length of each side and to mark off each side as they add the lengths together. Ensure that children are given centimetre squared paper to draw the shapes on to support their calculation of the perimeter.

Mathematical Talk

What is perimeter? How can we find the perimeter of a shape?

What do you think rectilinear means? Which part of the word sounds familiar?

If a rectangle has a perimeter of 16 cm, could one of the sides measure 14 cm? 8 cm? 7 cm?

Varied Fluency

- Calculate the perimeter of the shapes.

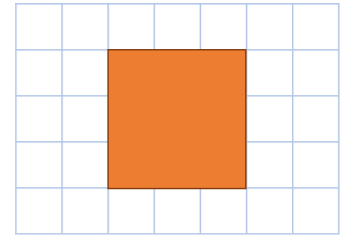
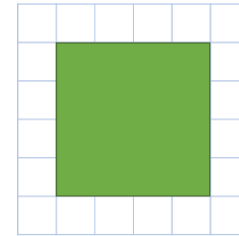
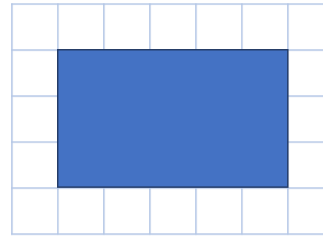

- Using squared paper, draw two rectilinear shapes, each with a perimeter of 28 cm. What is the longest side in each shape? What is the shortest side in each shape?

- Draw each shape on centimetre square paper.

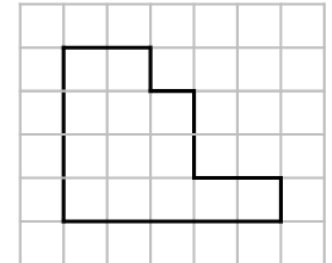
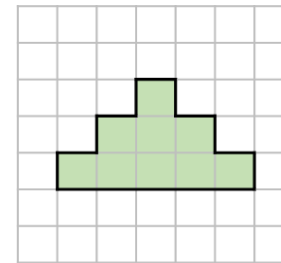
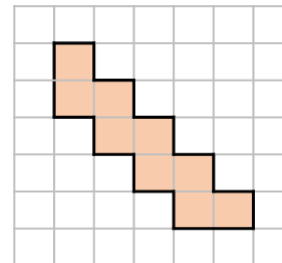

Order the shapes from smallest to largest perimeter.

Perimeter on a Grid

Reasoning and Problem Solving

Which of these shapes has the longest perimeter?

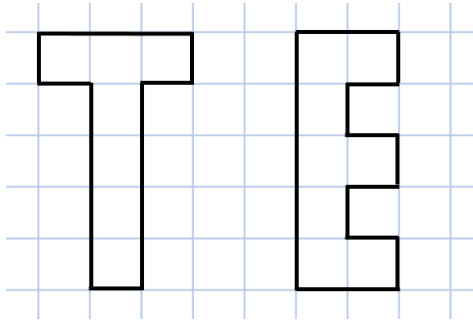

Explore other letters which could be drawn as rectilinear shapes.

Put them in order of shortest to longest perimeter.

Can you make a word?

E has a greater perimeter, it is 18 compared to 16 for T.
 Open ended.
 Letters which could be drawn include:
 B C D F I J L
 O P
 Letters with diagonal lines would be omitted.
 If heights of letters are kept the same, I or L could be the shortest.

You have 10 paving stones to design a patio. The stones are one metre square.

The stones must be joined to each other so that at least one edge is joined corner to corner.



Use squared paper to show which design would give the longest perimeter and which would give the shortest.

The shortest perimeter would be 14 m in a 2×5 arrangement or 3×3 square with one added on.

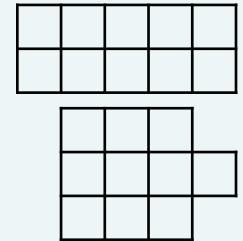

The longest would be 22 m.

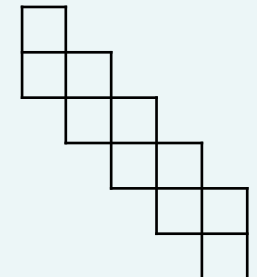

Perimeter of a Rectangle

Notes and Guidance

Children calculate the perimeter of rectangles (including squares) that are not on a squared grid. When given the length and width, children explore different approaches of finding the perimeter: adding all the sides together, and adding the length and width together then multiplying by 2

Children use their understanding of perimeter to calculate missing lengths and to investigate the possible perimeters of squares and rectangles.

Mathematical Talk



If I know the length and width of a rectangle, how can I calculate the perimeter? Can you tell me 2 different ways? Which way do you find the most efficient?

If I know the perimeter of a shape and the length of one of the sides, how can I calculate the length of the missing side?

Can a rectangle where the length and width are integers, ever have an odd perimeter? Why?

Varied Fluency

Calculate the perimeter of the rectangles.

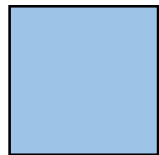
2 cm  5 cm 4 cm  10 cm 8 cm  8 cm

___ cm + ___ cm + ___ cm + ___ cm = ___ cm

Eva is finding the perimeter of the rectangle.



I added the length and width together and then multiplied by 2





5 cm  10 cm

$5\text{ cm} + 10\text{ cm} = 15\text{ cm}$
 $15\text{ cm} \times 2 = 30\text{ cm}$

Use Eva's method to find the perimeter of the rectangles.



6 m  16 m



9 cm  9 cm

Perimeter of a Rectangle

Reasoning and Problem Solving

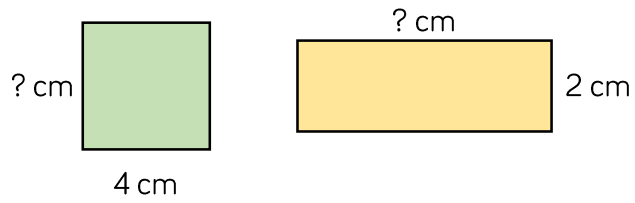
<p>The width of a rectangle is 2 metres less than the length. The perimeter of the rectangle is between 20 m and 30 m. What could the dimensions of the rectangle be? Draw all the rectangles that fit these rules. Use 1 cm = 1 m.</p>	<p>If the perimeter is: 20 m Length = 6 m Width = 4 m 24 m Length = 7 m Width = 5 m 28 m Length = 8 m Width = 6 m</p>
<p>Each of the shapes have a perimeter of 16 cm. Calculate the lengths of the missing sides.</p> 	<p>4 cm 6 cm</p>

<p>Always, Sometimes, Never When all the sides of a rectangle are odd numbers, the perimeter is even. Prove it.</p>	<p>Always because when adding an odd and an odd they always equal an even number.</p>
<p>Here is a square. Each of the sides is a whole number of metres.</p>  <p>Which of these lengths could be the perimeter of the shape? 24 m, 34 m, 44 m, 54 m, 64 m, 74 m</p> <p>Why could the other values not be the perimeter?</p>	<p>24 cm Sides = 6 cm 44 cm Sides = 11 cm 64 cm Sides = 16 cm They are not divisible by 4</p>

Perimeter of Rectilinear Shapes

Notes and Guidance

Children will begin to calculate perimeter of rectilinear shapes without using squared paper. They use addition and subtraction to calculate the missing sides. Teachers may use part-whole models to support the understanding of how to calculate missing sides.

Encourage children to continue to label each side of the shape and to mark off each side as they calculate the whole perimeter.

Mathematical Talk

Why are opposite sides important when calculating the perimeter of rectilinear shapes?

If one side is 10 cm long, and the opposite side is made up of two lengths, one of which is 3 cm, how do you know what the missing length is? Can you show this on a part-whole model?

If a rectilinear shape has a perimeter of 24 cm, what is the greatest number of sides it could have? What is the least number of sides it could have?

Varied Fluency

- Find the perimeter of the shapes.

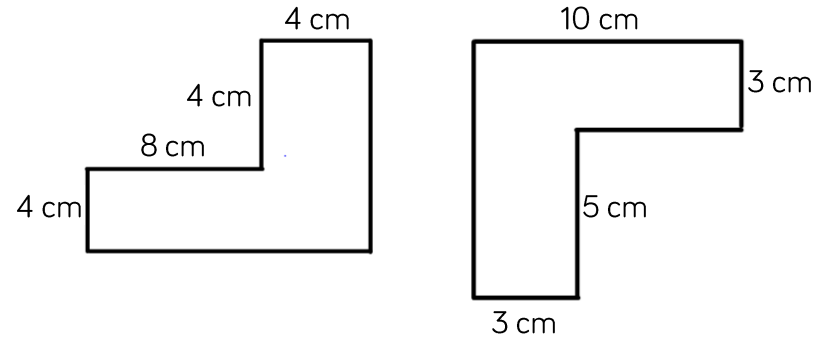

- The shape is made from 3 identical rectangles. Calculate the perimeter of the shape.

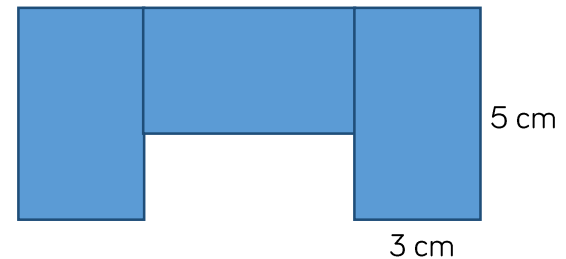

- How many different rectilinear shapes can you draw with a perimeter of 24 cm? How many sides do they each have? What is the longest side? What is the shortest side?

Perimeter of Rectilinear Shapes

Reasoning and Problem Solving

Here is a rectilinear shape. All the sides are the same length and are a whole number of centimetres.

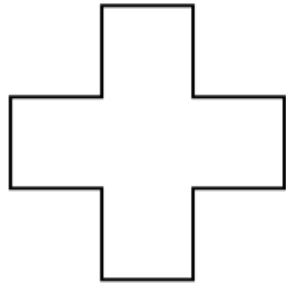

48 cm, 36 cm or 120 cm as there are 12 sides and these numbers are all multiples of 12

Any other answers suggested are correct if they are a multiple of 12

Which of these lengths could be the perimeter of the shape?

48 cm, 36 cm, 80 cm, 120 cm, 66 cm

Can you think of any other answers which could be correct?

Amir has some rectangles all the same size.

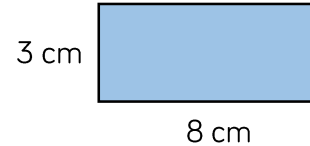

He makes this shape using his rectangles. What is the perimeter?

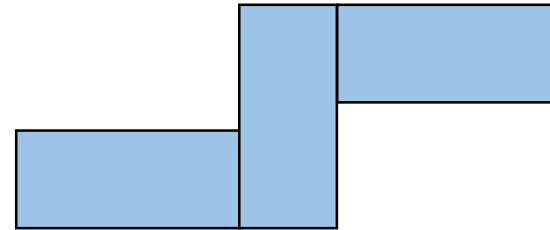

54 cm

He makes another shape using the same rectangles. Calculate the perimeter of this shape.

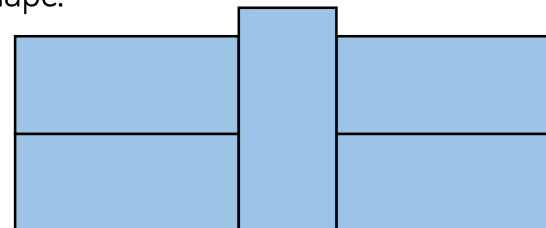

54 cm

Measure Perimeter

Notes and Guidance

Children measure the perimeter of rectilinear shapes from diagrams without grids.

They will recap measurement skills and recognise that they need to use their ruler accurately in order to get the correct answer.

They could consider alternative methods when dealing with rectangles e.g. $l + w + l + w$ or $(l \times w) \times 2$

Mathematical Talk

What is perimeter of a shape?

What's the same/different about these shapes?

Do we need to measure every side?

Once we have measured each side, how do we calculate the perimeter?

Varied Fluency

- Measure the perimeter of the rectangles.



- Measure the perimeter of the shapes.

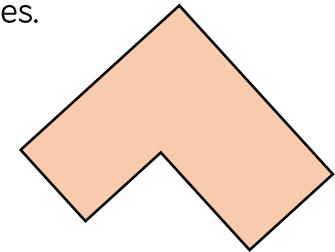
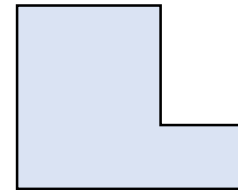

- Make this shape double the size using dot paper.

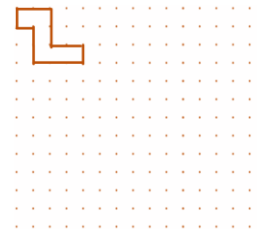

Measure the perimeter of both shapes.

What do you notice about the perimeter of the larger one? Why?

Measure Perimeter

Reasoning and Problem Solving

Each regular hexagon has a side length of 2 cm

Can you construct a shape with a perimeter of 44 cm?

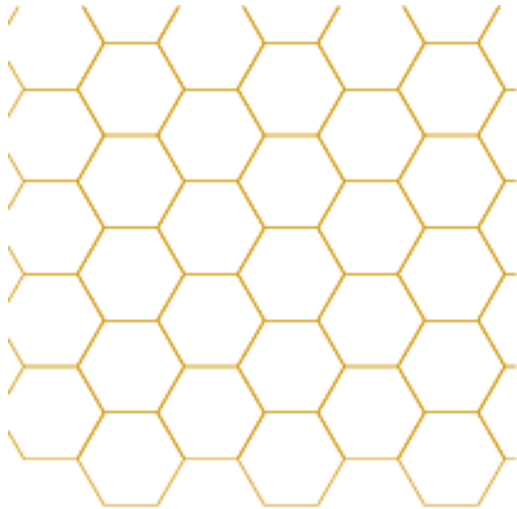

Possible answer:

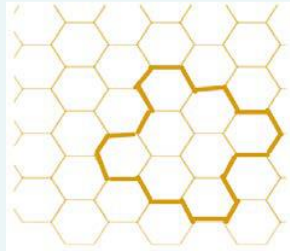

Discuss how many sides the shape must have with the children. Encourage their reasoning that there must be 22 2 cm sides to make a total perimeter of 44 cm.

Activity

Investigate different ways you can make composite rectilinear shapes with a perimeter of 54 cm.

Calculate Perimeter

Notes and Guidance

Children apply their knowledge of measuring and finding perimeter to find the unknown side lengths.

They find the perimeter of shapes with and without grids.

When calculating perimeter of shapes, encourage children to mark off the sides as they add them up to prevent repetition of counting/omission of sides.

Mathematical Talk

What can you tell me about the sides of a square/rectangle?
How does this help you work out this question?

How can you use the labelled sides to find the length of the unknown sides?

What strategies can you use to calculate the total perimeter?

What does regular mean? Why are rectangles irregular?

Varied Fluency

Find the perimeter of the following shapes.

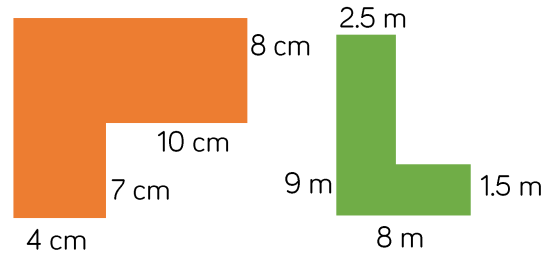

Each square has an area of 4 square cm.

What is the length of each square?

What is the perimeter of the whole shape?

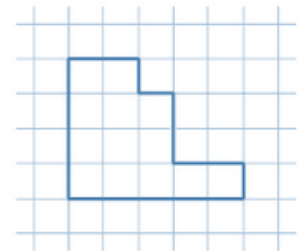

How many _____ can you draw with a perimeter of ____ cm?
e.g. rectangles, other rectilinear shapes.

How many regular shapes can you make with a perimeter of ____ cm?

Calculate Perimeter

Reasoning and Problem Solving

Here is a square inside another square.

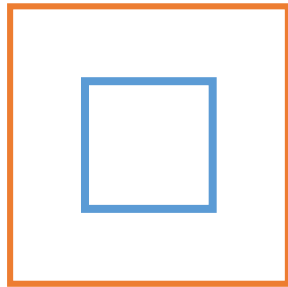

The perimeter of the inner square is 16 cm

The outer square's perimeter is four times the size of the inner square.

What is the length of one side of the outer square?

How do you know? What do you notice?

Small square = 16 cm

Large square = 64 cm

Length of one of the outer sides is 8 cm, because 64 is a square number.

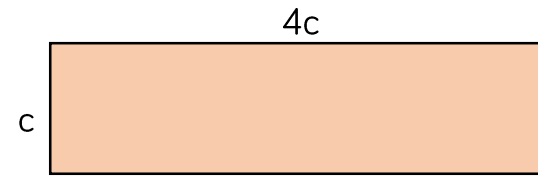

The value of c is 14 m.

What is the total perimeter of the shape?

$$4c + 4c + c + c = 10c$$

$$10 \times 14 = 140 \text{ m}$$

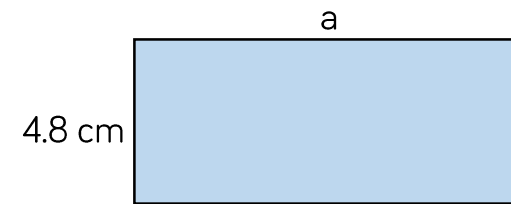

The blue rectangle has a perimeter of 38 cm.

What is the value of a ?

$$\text{Total perimeter} = 38 \text{ cm}$$

$$38 - (4.8 + 4.8) = 28.4$$

$$\text{So } 28.4 \text{ divided by } 2 = 14.2 \text{ cm}$$

White

**Rose
Maths**

Block 4 - Measurement

Theme 3 - Area

What is Area?

Notes and Guidance

Children are introduced to area for the first time. They understand that area is the amount space is taken up by a 2D shape or surface.

Children investigate different shapes that can be made with sets of sticky notes. They should be encouraged to see that the same number of sticky notes can make different shapes but they cover the same amount of surface. We call this the area of a shape.

Mathematical Talk

Use square sticky notes to find areas of different items in the classroom, which items have the largest surface area? Would we want to find the area of the playground using sticky notes? What else could we use? Why are shapes with perpendicular sides more effective to find the area of rectilinear shapes?

Varied Fluency



Which of the two shapes covers most surface?



How do you know?



This is a square sticky note.



Estimate how many sticky notes you need to make these shapes?

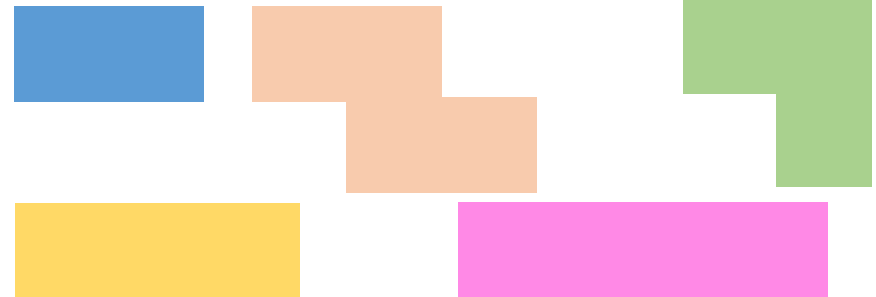

Now make the shapes using sticky notes. Which ones cover the largest amount of surface? Which ones cover the least amount of surface?

What is Area?

Reasoning and Problem Solving

Teddy and Eva are measuring the area of the same rectangle.

Teddy uses circles to find the area.

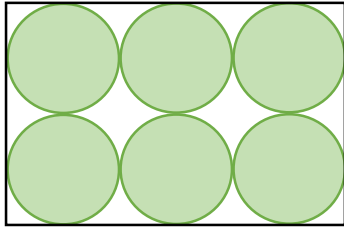

Eva uses squares to find the area.

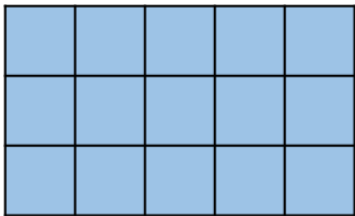

Whose method do you think is more reliable?
Explain why.

Possible answer:

Eva's method is more reliable than Teddy's because her squares cover the whole surface of the rectangle whereas the circles leave some of the surface uncovered.

Two children have measured the top of their desk. They used different sized squares.



Dora

The area of the table top is 6 squares.

The area of the table top is 9 squares.



Alex

Who used the largest squares?
How do you know?

Dora needed fewer squares to cover the space, so her squares must have been the larger ones. If the squares are smaller, you need more of them.

Counting Squares

Notes and Guidance

Once children understand that area is measured in squares, they use the strategy of counting the number of squares in a shape to measure and compare the areas of rectilinear shapes.

They explore the most efficient method of counting squares and link this to their understanding of squares and rectangles.

Mathematical Talk

- What strategy can you use to ensure you don't count a square twice?
- Which colour covers the largest area of the quilt?
- Which colour covers the smallest area of the quilt?
- Will Jack's method work for every rectilinear shape?

Varied Fluency

Complete the sentences for each shape.

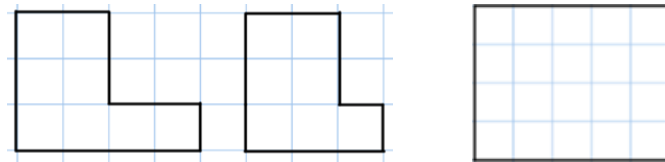

The area of the shape is ___ squares.

Here is a patchwork quilt. It is made from different coloured squares. Find the area of each colour.

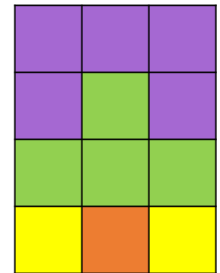

Purple = ___ squares Green = ___ squares
 Yellow = ___ squares Orange = ___ squares

Jack uses his times-tables to count the squares more efficiently.

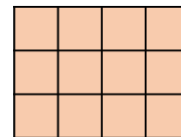

There are 4 squares in 1 row.
 There are 3 rows altogether.
 3 rows of 4 squares = 12 squares

Use Jack's method to find the area of this rectangle.

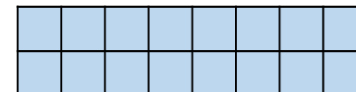

Counting Squares

Reasoning and Problem Solving

Dexter has taken a bite of the chocolate bar.

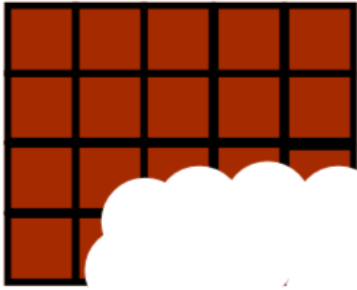

The chocolate bar was a rectangle. Can you work out how many squares of chocolate there were to start with?

There were 20 squares. You know this because two sides of the rectangle are shown.

This rectangle has been ripped.

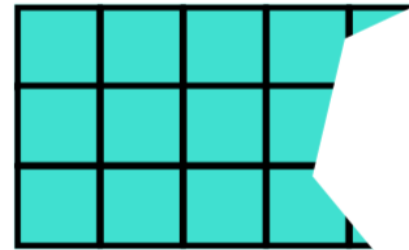

What is the smallest possible area of the original rectangle?

What is the largest possible area if the length of the rectangle is less than 10 squares?

Smallest area – 15 squares.

Largest area – 30 squares.

Making Shapes

Notes and Guidance

Children make rectilinear shapes using a given number of squares.

It is important that children understand that the rectilinear shapes they make need to touch at the sides not just at the corners. They can work systematically to find all the different rectilinear shapes by moving one square at a time.

Mathematical Talk

If you turn Ron's shapes upside down, do they stay the same or are they different?

Should you overlap the squares when counting area? Explain your answer.

How many different rectilinear shapes can you make with 8 squares? Will the area always be the same? Why?

Varied Fluency

- Ron has 4 shapes. He systematically makes rectilinear shapes.

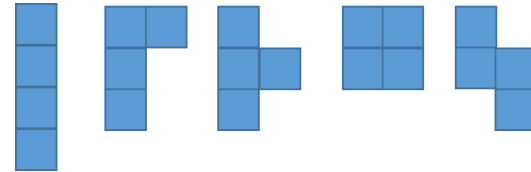

Use 5 squares to make rectilinear shapes. Can you work systematically?

- Use squared paper to draw 4 different rectilinear shapes with an area of 12 squares. Compare your shapes to a partner. Are they the same? Are they different?

- Mo is building a patio made of 20 square slabs. What could the patio look like? Mo is using 6 black square slabs in his design. None of them are touching each other. Where could they be in the designs you have made?

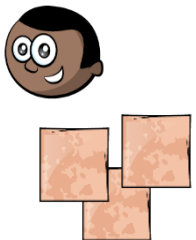

Making Shapes

Reasoning and Problem Solving

Here is a rectilinear shape.

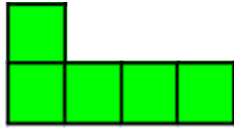

Using 7 more squares, can you make a rectangle?
Can you find more than one way?

Possible answers include:

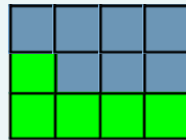
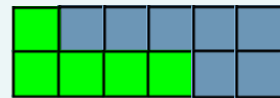
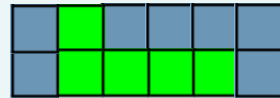

Can you make some capital letters on squared paper using less than 20 squares?

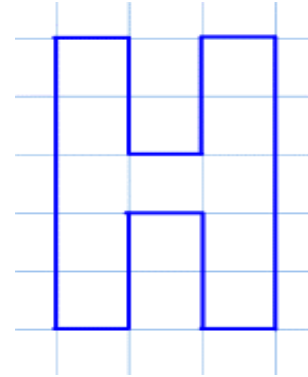

Make a word from some and count the total area of the letters.
Which letters have a line of symmetry?
What is the area of half of each letter?

Most letters can be made. They could be drawn on large squared paper or made with square tiles.

Comparing Area

Notes and Guidance

Children compare the area of rectilinear shapes where the same size square has been used.

Children will be able to use $<$ and $>$ with the value of the area to compare shapes.

They will also put shapes in order of size by comparing their areas.

Mathematical Talk

How much larger/smaller is the area of the shape?

How can we order the shapes?

Can we draw a shape that would have the same area as ___?

What is different about the number of squares covered by shape A?

Varied Fluency

Use the words 'greater than' and 'less than' to compare the rectilinear shapes.

Complete the sentence stems using $<$ and $>$

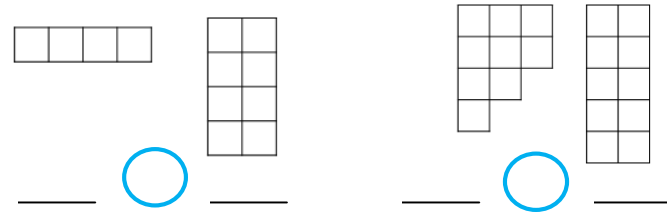

Put the shapes in order from largest to smallest area.

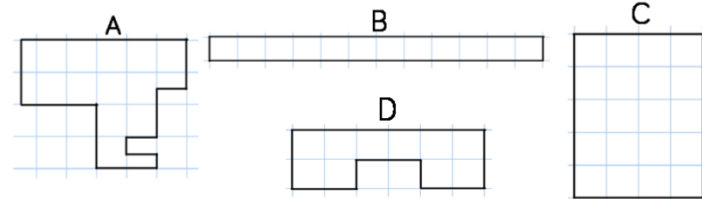

Here is a shape. Draw a shape that has a smaller area than this shape but an area greater than 7 squares. Draw a shape that has an area equal to the first shape, but looks different.

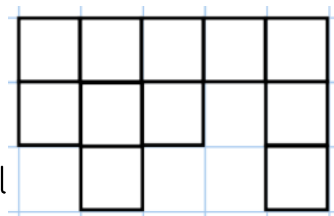

Comparing Area

Reasoning and Problem Solving

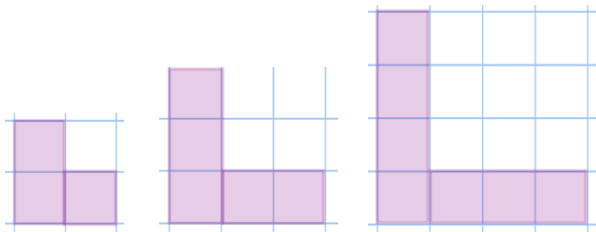

The area increases by 2 each time.

The next shape will have an area of 9.

The 6th shape will have an area of 13.

The answers are all odd numbers and increase by 2 each time.

Look at the shapes. Can you spot the pattern and explain how the area is changing each time?

Draw the next shape. What is its area?

Can you predict what the area of the 6th shape would be?

Can you spot any patterns in your answers?

Shape C has been deleted.

Area C > Area B

Area C < Area D

Can you draw what shape C could look like?

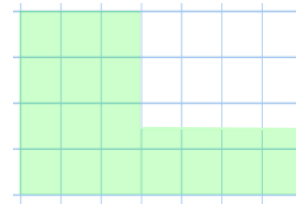

B

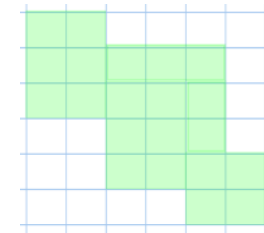

D

Shape A is missing too.

- It has the smallest area.
- It is symmetrical.

Can you draw what it could look like?

Shape B has an area of 18 squares.

Shape D has an area of 21 squares.

So Shape C can be any shape that has an area between 18 and 21 squares.

Shape A must have area less than 18 squares, but can be any symmetrical design e.g. a 4 by 4 square.

Area of Rectangles

Notes and Guidance

Children build on previous knowledge in Year 4 by counting squares to find the area. They then move on to using a formula to find the area of rectangles.

Is a square a rectangle? This would be a good discussion point when the children are finding different rectangles with a given area. For example, a rectangle with an area of 36 cm^2 could have four equal sides of 6 cm.



Mathematical Talk

What properties of these shapes do you need to know to help you work this out?

What can you tell me about the sides of a square/rectangle? How does this help you work out this question?

Will the formula 'Area = length \times width' work for any shape, or only squares and rectangles?

Varied Fluency

-  How many rectangles can you draw with an area of ____ cm^2 ?
-  What is the area of this shape if:
 - each square is 2 cm in length?
 - each square is 3.5 cm in length?

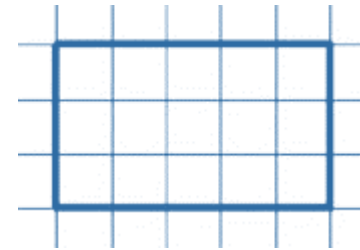

-  Mo buys a house with a small back garden, which has an area of 12 m^2 . His house lies in a row of terraces, all identical. If there are 15 terraced houses altogether, what is the total area of the garden space?

Area of Rectangles

Reasoning and Problem Solving

Investigate how many ways you can make different squares and rectangles with the same area of 84 cm^2
 What strategy did you use?

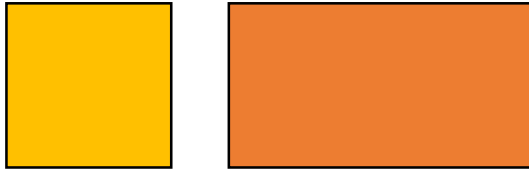

True or False?

If you cut off a piece from a shape, you reduce its area and perimeter.
 Draw 2 examples to prove your thinking.

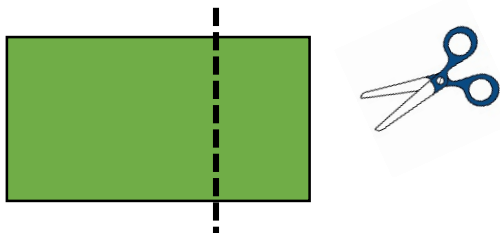

True

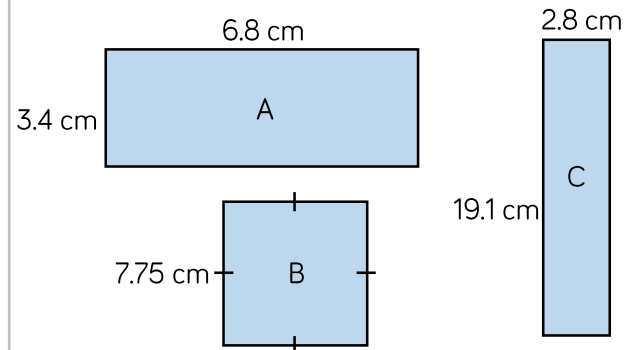

Estimate the area of each shape and then order from largest to smallest.

Answer: $A = 3\text{cm} \times 7\text{cm} = 21\text{cm}^2$
 $B = 8\text{cm} \times 8\text{cm} = 64\text{cm}^2$
 $C = 3\text{cm} \times 19\text{cm} = 57\text{cm}^2$

Order: B, C, A

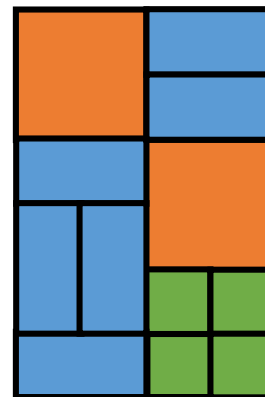

Each orange square has an area of 24 cm^2 .
 Calculate the total orange area.
 Calculate the blue area.
 Calculate the green area.
 What is the total area of the whole shape?

Answer:
 Orange = 48 cm^2
 Blue = 72 cm^2
 Green = 24 cm^2
 Total = 144 cm^2

Area of Compound Shapes

Notes and Guidance

Children learn to calculate area of compound shapes. They need to be careful when splitting shapes up to make sure they know which lengths correspond to the whole shape, and which to the smaller shapes they have created. They will discover that the area remains the same no matter how you split up the shapes.

Children need to have experience of drawing their own shapes in this step.

Mathematical Talk

What formula do we use to find the area of a rectangle?

Can you see any rectangles within the compound shapes?

How can we split the compound shape?

Is there more than one way?

Do we get a different answer if we split the shape differently?

Varied Fluency

- Find the area of the compound shape:
How many ways can we split the compound shape?

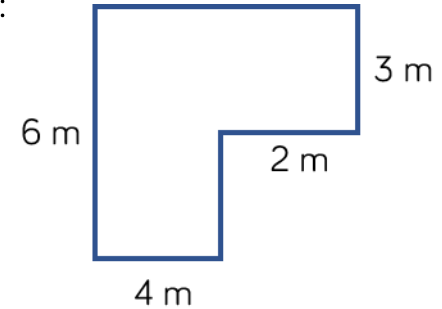

Is there more than one way?

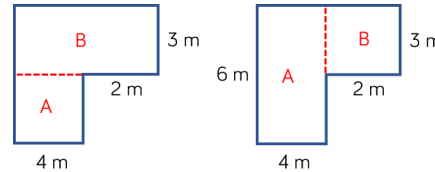

Could we multiply $6\text{ m} \times 6\text{ m}$ and then subtract $2\text{ m} \times 3\text{ m}$?

- Calculate the area.

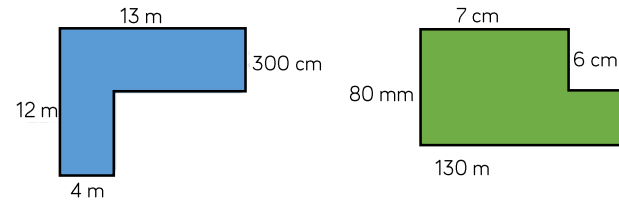

- Calculate the area of these symmetrical shapes.

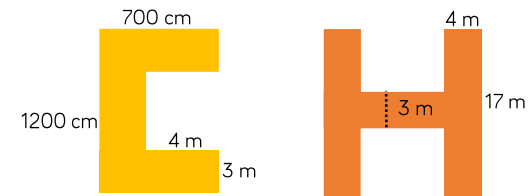

Area of Compound Shapes

Reasoning and Problem Solving

How many different ways can you split this shape to find the area?

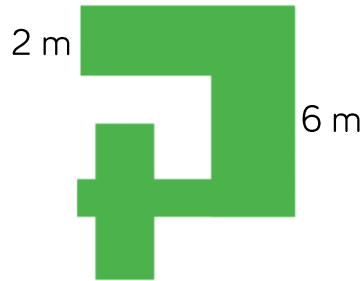

Add more values and work out the area.

Possible solution:

$$A = 2 \text{ m} \times 5 \text{ m} = 10 \text{ m}^2$$

$$B = 6 \text{ m} \times 3 \text{ m} = 18 \text{ m}^2$$

$$C = 1 \text{ m} \times 2 \text{ m} = 2 \text{ m}^2$$

$$D = 1 \text{ m} \times 8 \text{ m} = 8 \text{ m}^2$$

$$E = 3 \text{ m} \times 2 \text{ m} = 6 \text{ m}^2$$

$$\text{Total area} = 36 \text{ m}^2$$

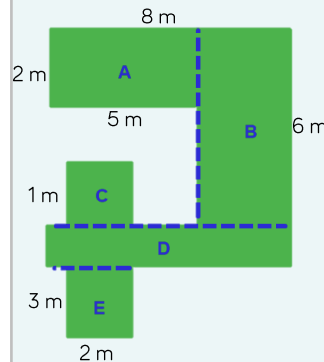

Jack says this shape has an area of 34 cm^2 .

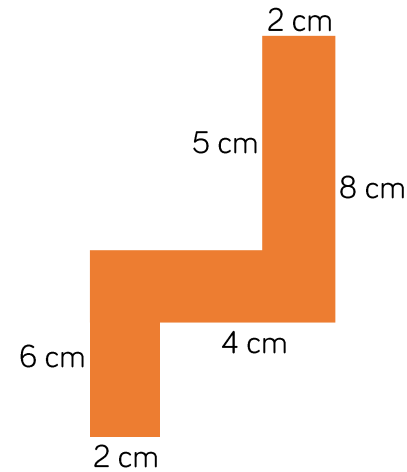

Show that Jack is correct.

Find three more possible compound shapes that have an area of 34 cm^2 .

Possible solution:

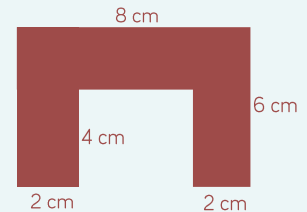

Area of Irregular Shapes

Notes and Guidance

Children use their knowledge of counting squares to estimate the areas of shapes that are not rectilinear. They use their knowledge of fractions to estimate how much of a square is covered and combine different part-covered squares to give an overall approximate area.

Children need to physically annotate to avoid repetition when counting the squares.

Mathematical Talk

How many whole squares can you see?

How many part squares can you see?

Can you find any part squares that you could be put together to make a full square?

What will we do with the parts?

What does approximate mean?

Varied Fluency

- Estimate the area of the pond.
Each square = 1 m²



Ron's answer is 4 whole squares and 11 parts.
Is this an acceptable answer?

What can we do with the parts to find an approximate answer?

- If all of the squares are 1 cm in length, which shape has the greatest area?

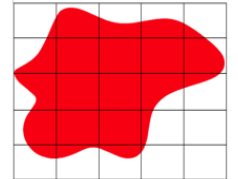
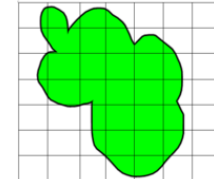
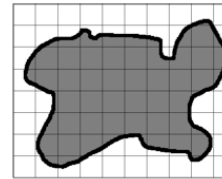

Is the red shape the greatest because it fills more squares?

Why or why not?

What is the same about each image? What is different about the images?

- Each square is ___ m²
Work out the approximate area of the shape.

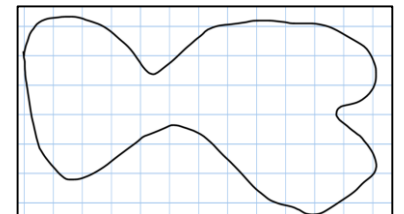

Area of Irregular Shapes

Reasoning and Problem Solving

Draw a circle on 1 cm² paper. What is the estimated area?
 Can you draw a circle that has area approximately 20 cm²?

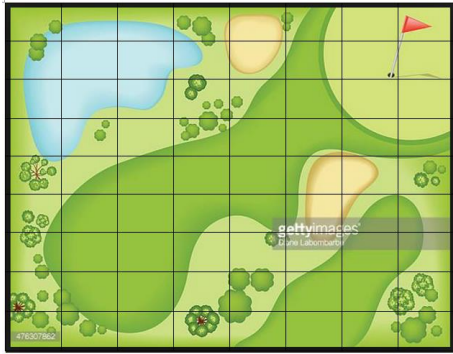

If each square represents 3 m², what is the approximate area of:

- The lake
- The bunkers
- The fairway
- The rough
- Tree/forest area

Can you construct a 'Pirate Island' to be used as part of a treasure map for a new game? Each square represents 4 m².

The island must include the following features and be of the given approximate measure:

- Circular Island 180 m²
- Oval Lake 58 m²
- Forests with a total area of 63 m² (can be split over more than one space)
- Beaches with a total area of 92 m² (can be split over more than one space)
- Mountains with a total area of 57 m²
- Rocky coastline with total area of 25 m²